

## So What Really is a “Glue Line Cut”?

Much has been said and claimed about the edge cutting capabilities of various wood processing rip saws available on the market today. In specific, it appears that virtually every rip saw offered today, whether new or used, undercutting or overcutting, single or multiple blade, claims that it can produce an “eight foot glue line”. As the manufacturers of straight line rip saws since 1923, the year that the term was coined, we think the issue about the phrase “glue line cut” needs to be explained and qualified so that those who use the term do so properly and do not misrepresent its true, original, and current meaning.

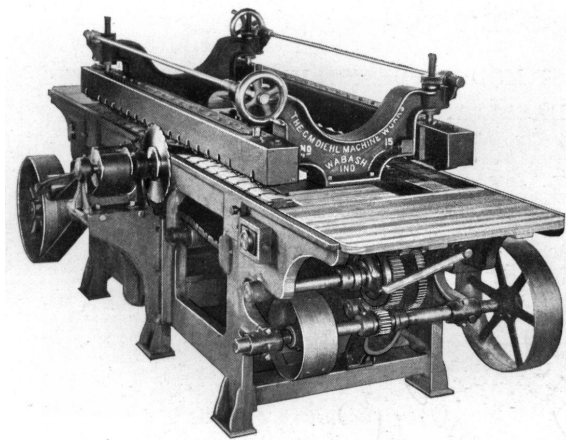

*The Model 15, Diehl's first rip saw, was introduced in 1913. It established the foundation for all subsequent Diehl saws... the undercutting principle.*

Diehl Machines claims unique authorship of the term “glue joint” or what has developed into the more common phrase of today... “glue line”, beginning in 1923 with the introduction of its Model No. 55. Though Diehl introduced its first undercutting, chain fed rip saw (Model 15) in 1913, the No. 55 was the evolution of the Model 44, identified in Cosgrove's Handbook of Woodworking Machinery as a jointer/saw type. The Model 44, a single chain machine, was the first saw specifically designed to create a “glue joint or glue line”, not just attempt to cut a straight line on lumber for subsequent processing. This machine also offered a lay-up table feature, utilizing the skill of the off bearer to begin arranging the core stock into defined panel widths.

Up to this point in wood processing, the accepted means for preparing edge glued stock was to rip lumber to a nominal straight edge and then create the smooth glue-able edge surface with a manual hand fed type or power fed lumber jointer. Processing panel stock edges was a two-step process, and running boards over a lumber jointer for making either straight or “sprung” edges was employed. The Diehl Model 30 is mentioned in the handbook as a model available for use in this application, among others manufactured by Yates, Jenkins and Fay & Egan.

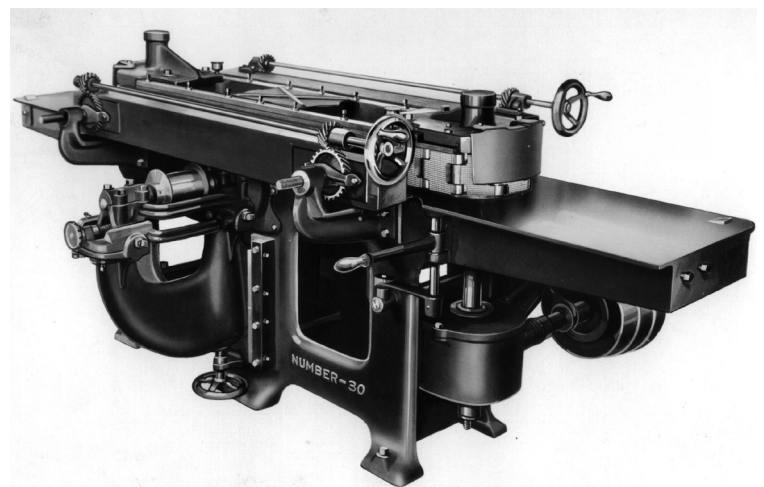

*Diehl Model 30 lumber jointer, introduced in 1918. The 30 featured the ability to produce the “sprung edge”, or what was to become known as the “hollow” or “glue line” cut.*

In 1923, George Cosgrove's Handbook of Woodworking Machinery identified the most comprehensive list of domestic woodworking machinery builders.

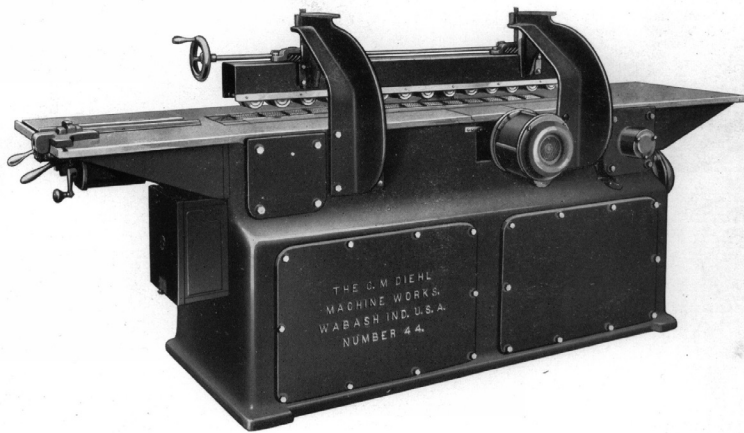

*In 1922, Diehl introduced the Model 44, the saw jointer. It was the first saw to offer the ability to create the hollow or sprung cut - eliminating the secondary jointing operation.*

Their literature makes mention of its glue-joint work by properly preparing and jointing the saw blades to achieve a straight cut, something entirely different than the hollow cut, or the glue line claimed by Diehl. All of the above machines identified by Cosgrove in 1923 were upper cutting saws and were designed to create a true cut...meaning that when fitted with a proper saw blade, they were intended to create glue joints for both core stock and face work. However, cutting from above with a single piece lower feed chain below requires that the blade cut the stock as the teeth travel in and out of the material, and leaves some degree of crosshatch finish, depending on the quality of the blade. But the Diehl saw used a different design principle. The Diehl Model 55 differed in that it cut from the bottom, with two chains carrying the material past the blade.

The Model 55 was the first dual, side by side chain, undercutting rip saw that had the ability to create a hollow cut (what was identified on a lumber jointer as a sprung joint) on the lumber's edge for a significantly improved degree of clamping panel stock. And it is that precise fact, ***the ability to create a high quality hollow joint when two pieces of panel stock are placed side by side, that really defines a glue joint or glue line.*** Using the term to mean any other kind of cut is a misrepresentation of the facts. Diehl certainly recognizes that lumber can be glued and joined together without a glue joint cut on the adjoining edges; but the effort required, the qualitative results and the integrity of that contact surface are the issues being presented.

At the time of Cosgrove's publication, the Diehl Model 55 was being completed and readied for introduction as a replacement for the Model 44. George Diehl recognized the opportunity to develop a new machine that would be a more versatile saw to rip lumber and create the high quality edge necessary to prepare panel stock when going directly to the clamp. Therefore, the 55 included three totally new features.

Consequently, there is no question that prior to 1923 firms were manufacturing chain fed saws that performed a ripping operation for the secondary lumber jointing process to produce glued up panels, because Diehl Machines was a member of that group. The Mattison Machine Works, the J. A. Fay & Egan Company, P. B Yates Machine, Hermance Machine Works and American were among the most prominent builders of saws for that purpose as well. Mattison promoted their models 205 & 207 (both mentioned in that handbook) in their December 1930 brochure, prominently identifying the saw as a Jointer-Ripper-Edger...but not a straight line rip saw.

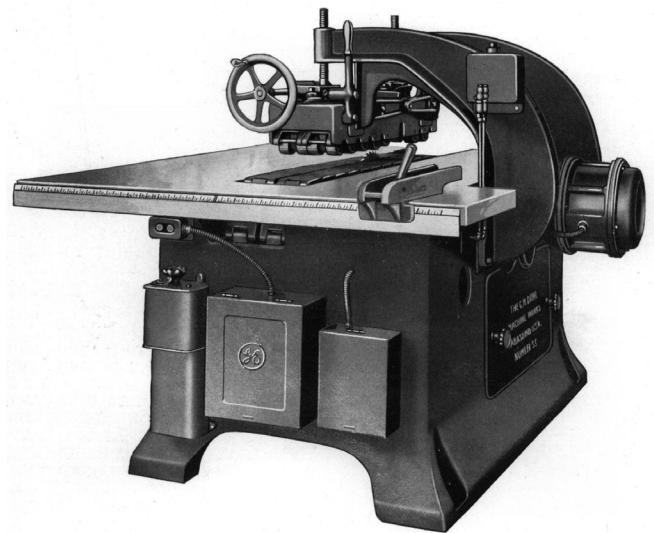

*In late 1923, the Model 55 offered the first dual lower chain rip saw for glue line or straight cut ability, creating the same operation principles found in today's Diehl rip saw.*

First, the chain's tracking mechanism involved a series of v-grooves on the link's lower surface, and the dual lower chain made edging on either side of the board more convenient.

Second, the lower chains positioned on either side of the blade traveled in a path that was not absolutely parallel to the blade...they each diverged away from the blade ever so slightly on either side.

Third, the non-driving or idle end of the chain did not travel in a wheel or rotary element. Instead, the chain traveled in a circular raceway that could influence the tracking of the lumber.

The combined effect of these features was to offer a machine that could:

- Eliminate the two-step rip and jointing process by combining those functions into one reliable process.
- Produce a consistent, high quality cut because the stock moved slightly away from the blade as the cut was complete, eliminating the crosshatch marks.

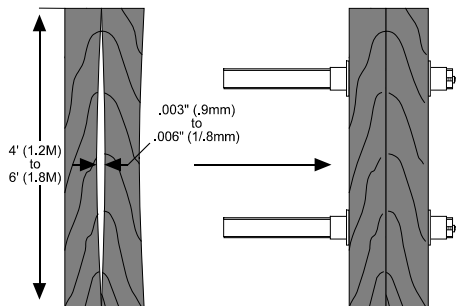

The sprung or hollow cut would eventually become known as the "glue line" cut.

The "sprung" cut, as identified in 1923 was in fact the hollow cut Diehl was now able to produce on its Model 55. The term "sprung" was used to describe the spring-loaded or slightly hourglass configuration/condition of the board being prepared for clamping. Because the center of the board's width was slightly narrower than the ends, the effect of the clamp was to cause a tighter fit at the ends, minimizing "end checking" or splitting, a common problem in clamping panel stock.

The "end checking" problem in panel construction can result for several reasons. When the panel stock component edges are straight and mechanically clamped nearer to the center, the concentrated force of the clamps squeezes only in the center, forcing the ends open where possible. The inconsistent nature of wood structure makes end checking an erratic occurrence. However, the likelihood of end checking is greater when clamping in the center with straight stock as compared to the hollow edged or sprung panel stock. The Diehl design provides both a means to rip lumber with an extremely high quality of cut, and to use a simple mechanical principle to create a higher degree of clamping integrity.

At the turn of the century, lumber jointers were developed with a system that altered the chain's path as it moved past the cutter head, creating the sprung board or hollow cut. Diehl's Model 30 was one such machine. On Diehl's new Model 55, the straight or hollow cut was capable of being achieved, depending on the user's requirements, in addition to creating a superior edge surface. However, unlike the lumber jointer that required the lumber be fed on edge, Diehl's Model 55 allowed the stock to be fed flat on its face, a provision that provided for greater defecting capability. By 1927, Diehl had introduced a larger saw and an improved method for chain control, but both basic systems remain in today's Diehl straight line rip saw.

The ripping of lumber and gluing those random width components into panels presents many challenges to the manufacturer who chooses this process. Even with the machine's ability to produce the hollow cut, not every piece of wood results in a usable component. The random nature of wood itself makes every piece different in grain, density, and internal stress. In many cases, this variation exists in different areas of the same piece of wood! Given our 85 year history of producing integral equipment

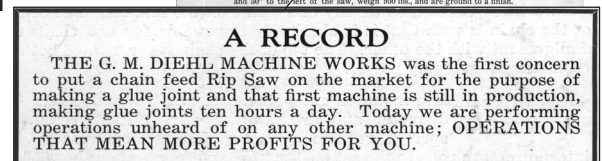
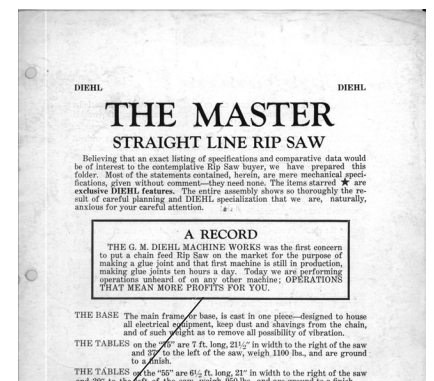

**In March 1927 Diehl introduced the Model 75 Master Saw, a larger version of the model 55 with greater speed & thickness capacity. This page from the 75's initial literature specifically talks about cutting a glue joint, on a Diehl straight line rip saw... the first evidence of that claim being made by a rip saw builder.**



for the manufacture of high quality wood panels, Diehl Machines has unique experience in this process. While high quality, solid wood panel production continues to present most of the same basic challenges today as it did many years ago, Diehl Machines can offer a unique wealth of information about the ripping process.

The fact remains though, that no over cutting, single lower chain saw can produce the same high quality of straight cut, nor can it produce the hollow or sprung cut achieved on the Diehl rip saw. And though replications have been attempted, these other saws cannot consistently perform the same quality straight or hollow cut on the edge of panel stock.

The same undercutting, dual chain principle remains today in the Diehl Straight Line Rip Saw. The Models SL35 and SL30 are current day generations of the original Model 55 and Model 33, while the SL65 represents the full size machine originally introduced as the Model 75 in 1927. But the ability to produce the straight cut usually associated with edging in lumber mills...or the glue line required in most panel production mills remains the same. See the full line of Diehl woodworking equipment serving the wood processing industry since 1909!

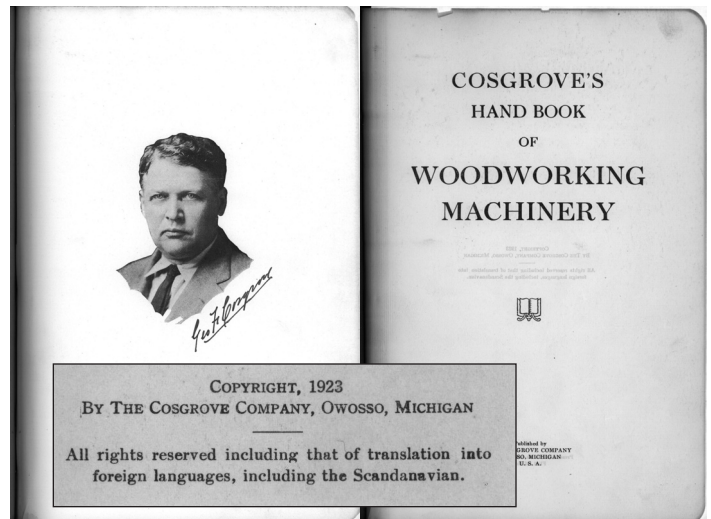

*"Cosgrove's Handbook" was published in 1923, by George Cosgrove, a consultant to the woodworking industry. His compendium of domestic machinery available in the market represented the most comprehensive publication of it's kind for many years. Supplements were added throughout the 1920's and in 1937, a final addendum was published.*



For more information about the hollow "glue line" developed by Diehl Machines on its straight line rip saw, contact Diehl Machines.



**DIEHL MACHINES**

P.O. Box 465, Wabash IN 46992 · 260-563-2102 · US FAX for Parts and Service 1-800-228-9115  
International FAX 260-563-0206 · [www.diehlmachines.com](http://www.diehlmachines.com)